

60KG MINI
Electromagnetic lock



EL-100



EL-H100

Specifications

EL-100 Size	80Lx38Wx23H(mm)
EL-H100 Size	114Lx35Wx23H(mm)
Holding Force	60KG(100Lbs)
Voltage	DC12V or DC24V
Working Current	12V/160mA 24V/200mA
Suitable for	File Cabinet, Disply Cabinet
Operating temp	≤20°C
Surface temp	-10 °C ~ 55 °C (14°F~131°F)
Suitable humidity	0~90% (non-comdensing)
Finishes for shell	Anodized aluminum surface texture processing
Finishesfor magnetic	Zinc
Finishes for armature	Zinc
Weight	0.6kg
Standard packing	60pcs

Dimensions

EL-100
80Lx38Wx23H(mm)

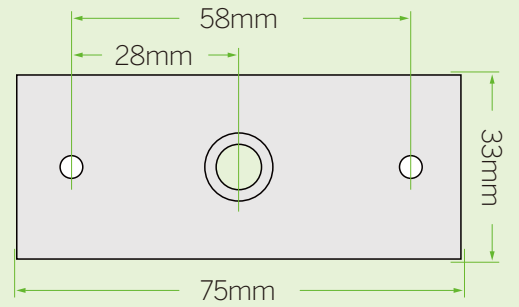
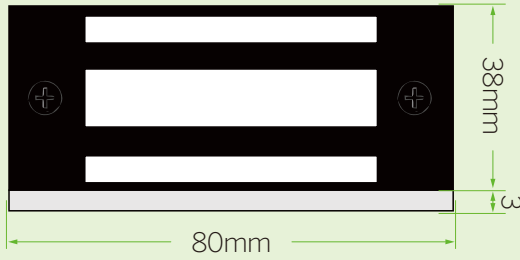

EL-H100
114Lx35Wx23H(mm)

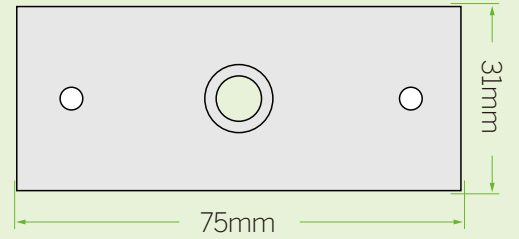
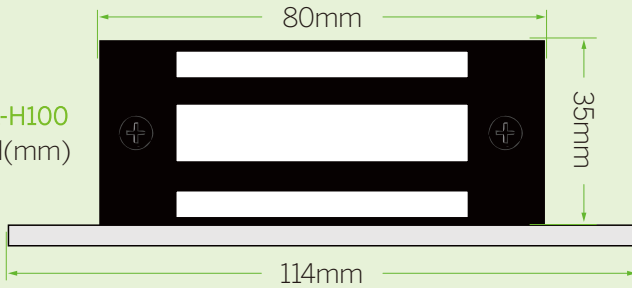

Wiring diagram

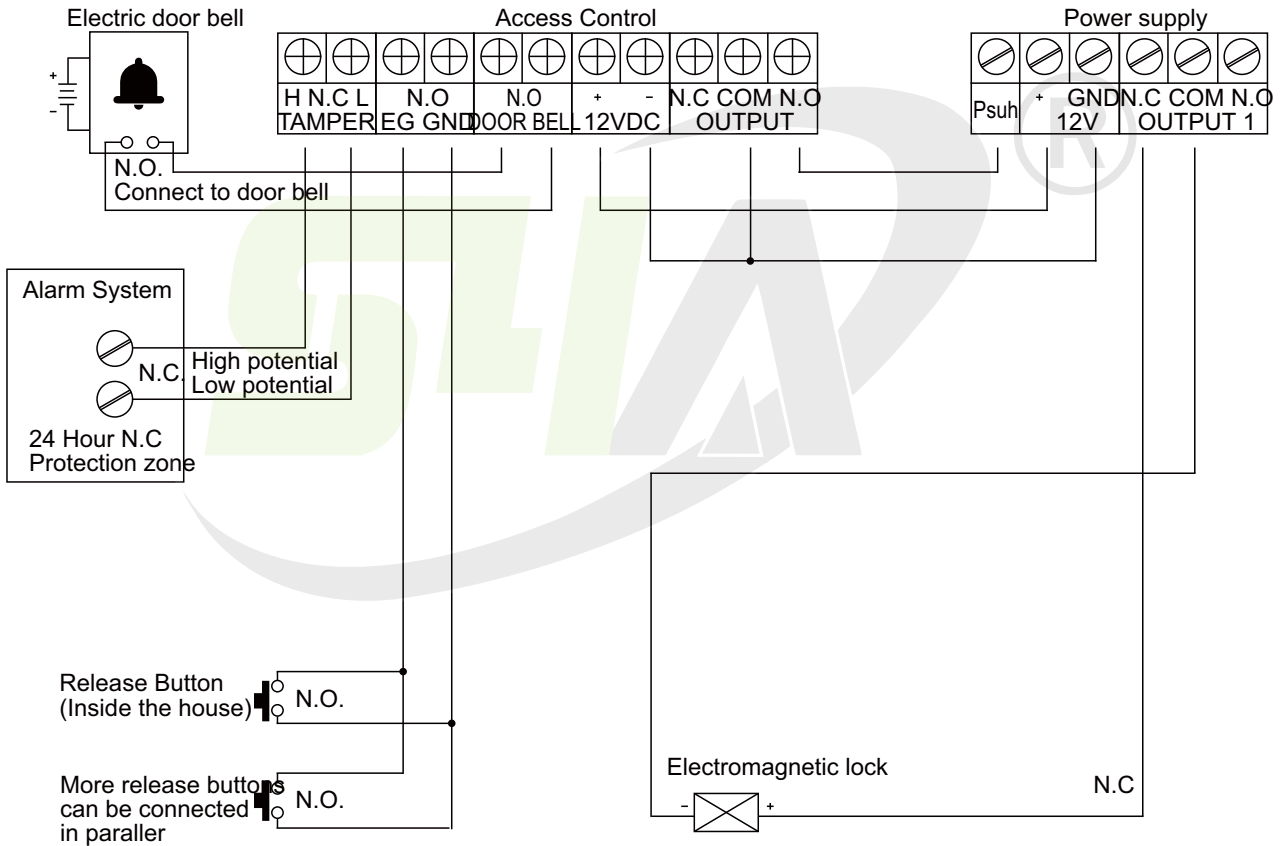

S4A Industrial Co., Limited

Address: The 2nd floor, Jinmin'an Industrial Zone, #529, Bulong Rd.
Bantian St. Longgang Dist. Shenzhen, PRC.. CN 518131



Tel: +86 755 29450011

www.s4a-access.com / Email: sales@s4a-access.com
Mob/Whatsapp/Wechat/Viber: +86 134 1050 0721